

# INNOMOTICS

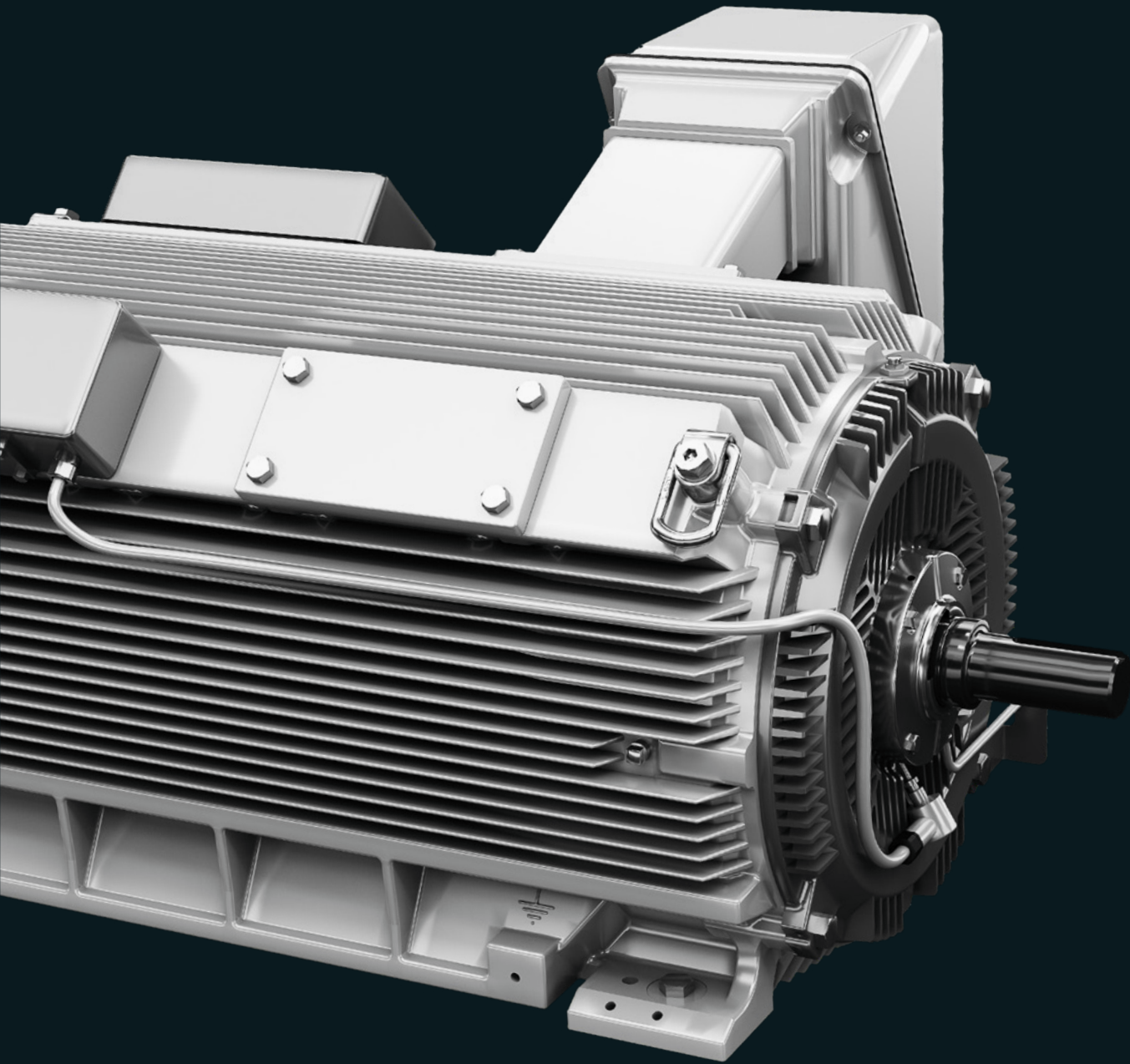

## **Innomotics Moves!**

**Medium Voltage Motors  
Advantage Series™**



With a trusted legacy of more than 150 years of engineering expertise, we are and have always been the backbone of reliable motion for industries and infrastructure worldwide. Now, we're about to take this to the next level with Innomotics.

To support you, our customers and partners, and your business on the road to the future – sustainable, digital, reliable.

#### **Experience is built in.**

The Advantage Series medium voltage totally enclosed fan-cooled motor design is a result of meeting the common application challenges users experience with large compressors, blowers, coolers, mixers, conveyors, extruders, and pumps among many others.

#### **We meet or exceed industry preferred standards.**

Motor operators rely on standards to assure performance and Innomotics has always been at the forefront of compliance with important industry standards.

- IEEE841 Features
- ANSI
- NEMA
- CSA
- CSA - US
- NEMA Premium® Efficiency

**“There is growing demand for large, low-spec, high quality, stocked motors with a robust set of standard features and pre-engineered modifications.”**

#### **Well suited for a wide range of industries and applications.**

We understand that many industries have common large rotating applications that are low-spec in nature. Users also prefer motor suppliers that are capable of delivering standard and customized equipment. We are one of the few manufacturers today that effectively do both.

- Petroleum & Chemical Processing
- Mining & Minerals
- Cement
- Marine
- Metal Producing and Processing
- Water & Wastewater
- Power Generation
- Fiber / Pulp & Paper
- Industrial Refrigeration

**Advantage Series is a standard TEFC motor best suited for low specification applications in a wide range of industries.**

# Advantage Series

## Medium Voltage Motor Key Features

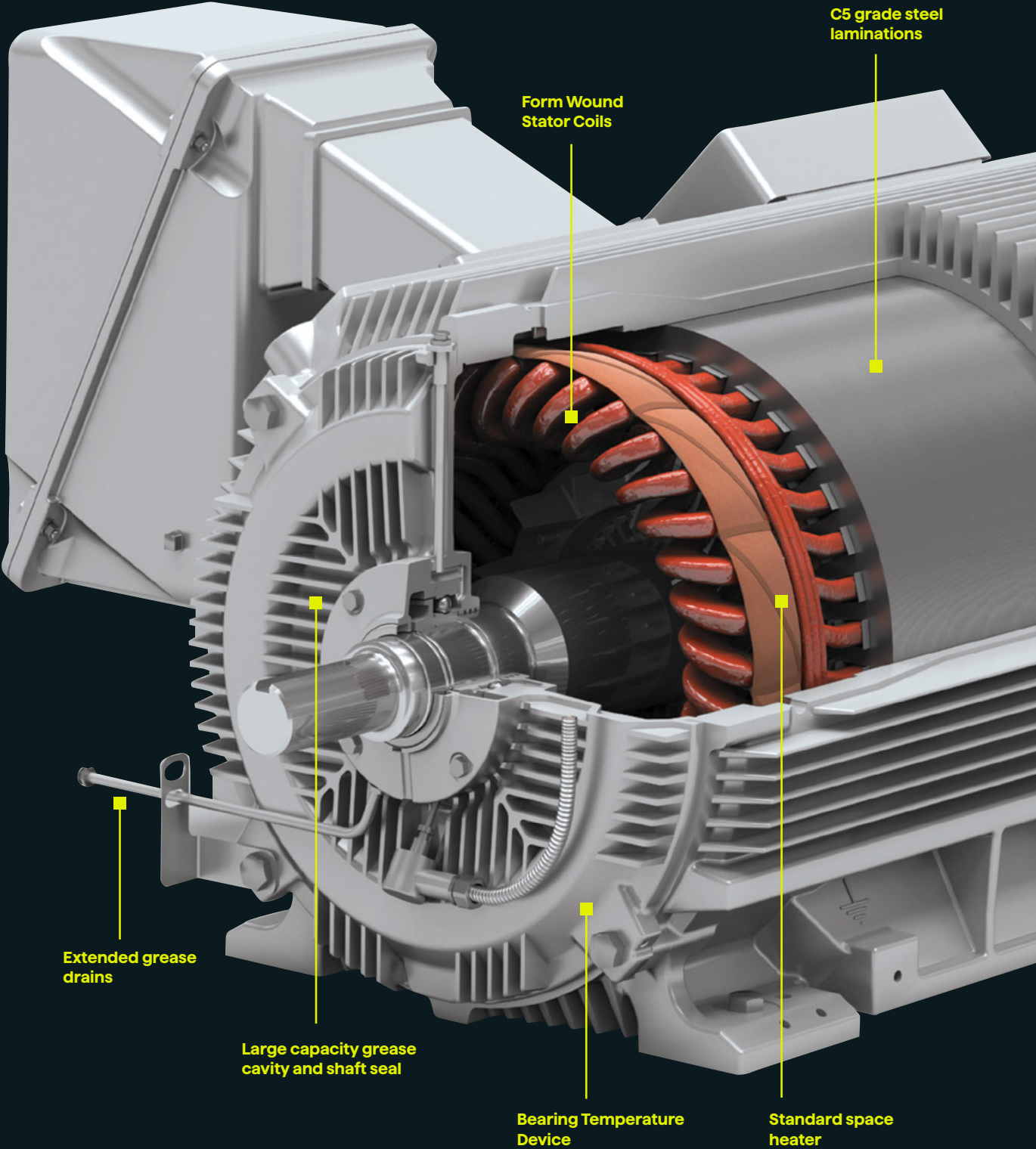

Form Wound  
Stator Coils

C5 grade steel  
laminations

Extended grease  
drains

Large capacity grease  
cavity and shaft seal

Bearing Temperature  
Device

Standard space  
heater

Innomotics has engineered a cost-efficient design that offers users one of the most robust and reliable standard medium voltage motors in the industry.

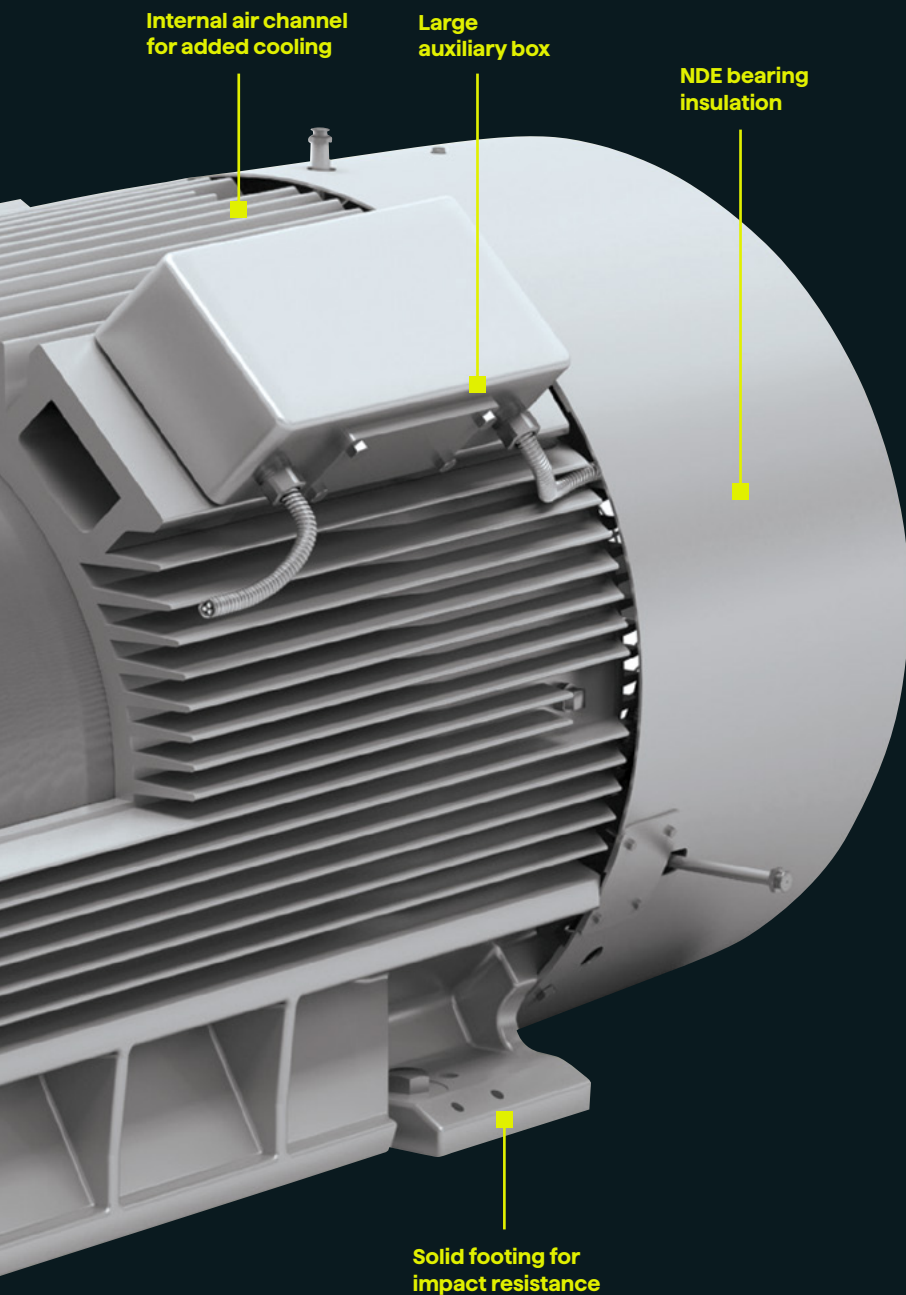

### **Frame and End Shields**

Enclosed in a cast iron frame, end shields, and a durable main terminal box. Features high strength zinc-plated hardware, epoxy paint, and stainless-steel nameplates resistant to rust and corrosion for harsh environments.

### **Rotor and Stator Windings**

A high-strength carbon steel shaft holds a dynamically balanced die cast aluminum rotor assembly for maximum performance, efficiency, and bearing life. The stator is manufactured with C5 grade steel lamination and copper magnet wire designed to minimize electrical losses.

### **Insulation**

Advantage Series motors utilize the MICALASTICTM insulation system, a vacuum pressure impregnation (VPI) insulation free of gaps or voids. It meets the insulation requirements for MG1 Part 31 with a 6kV rated insulation system.

### **Cooling System**

All rotor fans are designed to meet most CSA Class II areas and are bi-directional except for larger 2 pole machines. Its fan design improves cooling while reducing windage losses and noise. It is protected by a cast iron fan cover on all frame sizes.

### **Bearings**

Single shielded with sealed bearings on both drive end and non-drive end are designed for easy serviceability and protection against contaminants.

# Technical Details

## Construction Features

Enclosure	TEFC (IC411)
Degree of Protection	IP55
HP Range	400 - 1100 HP (2, 4 pole), 300 - 900 HP (6 pole)
Frame Size / Shaft Hgt.	5011, 5810, SH400
Voltage	2300V/4000V
Service Factor	1.15 @ 40°C
Warranty	36 months from date of manufacture

## Construction Materials

Frame	Cast Iron
Bearing Housings	Cast Iron
Main Terminal Box	Cast Iron
Auxiliary Boxes	Cast Iron - NEMA 4X
Shaft	1045 equivalent (2 pole), 4140 equivalent (4,6 pole)
Rotor	Aluminum Die Cast
Lamination Material	C5 Core Plate
External Cooling Fan	Anti-Static Reinforced Polyamide
Fan Cover	Cast Iron
Insulation	MICLASTIC™ VPI
Hardware	Zinc Plated Carbon Steel

## General Information

Noise Level	85 dB(A)
Vertical Mounting	N/A
Inverter Operation	"Meets NEMA MG1-31 rated at 6kV Variable Torque: 10:1; Constant Torque: 2:1"
Paint	Two-part Epoxy
Paint Color	RAL 7030 Gray
Bearing Type	Anti-friction ball
Vibration	0.12 IPS
Hazardous Area	CSA Class 1, Division 2, Groups B, C, D, Temp Class T3 (5011 frame on VFD Temp Class T2D)
Protection	Space Heater: 120/240 Volt Stator RTDs, 2/ph: 2-wire Bearing RTDs, 1/brg: 2-wire

# Additional Options

## Roller Bearings

Motors having roller bearings require a minimum radial load. Use of these motors in direct connected applications is discouraged to avoid excessive drive end bearing noise and/or reduced bearing life.

## Additional Nameplate with Values for Derating

Innomotics will provide a quick review and update the standard nameplate with a new one reflecting updated ratings.

## Direction of Rotation

All 2 pole motors are "Uni-directional" and will be listed CW as standard.

## IEEE 841 Standard - 2009

This standard applies to premium-efficiency TEFC's up to 500 horsepower and 4000 volts. It is used in petroleum, chemical, and other severe-duty applications. For 2 pole motors, exception is taken to sound power levels and data is offered in sound pressure.

## Nameplate Additions

Multiple options are available to include specific information on your nameplates.

## Shaft Seals

For IP56 and/or specific Inpro/Seal on the drive-end.

Code	Description
MLFB	C-Face (Digit 12, Change to 5)
MLFB	D-Flange (Digit 12, Change to 6)
D44	Division 2 Nameplate (Class I, Div 2, Grps B,C,D, Temp. Class T3) (5011 frame on VFD will be T2D)
K08	F-1/2/3 w/ Top-Mount Spacer
K09	F-2 Assembly
K20	Roller Bearings
K44	Additional Nameplate (Replica of original)
K51	IP56 Shaft Seal
K91	Inpro Seal - Drive End (Included on R61)
K92	Inpro Seal - Opposite Drive End (Included on R61)
K97	Clockwise Rotation Arrow
K98	Counterclockwise Rotation Arrow
L18	Insulated Bearing, DE & NDE
L29	Low Noise Fan Housing
L70	NEMA Type I, Fab Steel (FS1.5 - 13900 cu.in. volume)
L77	Sealed leads (Chico)
R03	Robert Shaw vibration switch
R05	Provision for vibration sensors, PMC/Beta
R08	Provisions for Accelerometer/Velometer - Golf Tee
R30	Tachometer
R39	Shaft Grounding, Ground Brush DE
R45	Stainless Steel 304 Series Hardware
R57	Stainless Steel Breather Drain
R61	IEEE 841 Features, with Inpro Seals on DE & NDE
S98	Sea Freight Packaging - Siemens Standard
Y80	Additional nameplate with values for derating
Y82	Auxiliary Nameplate, max 40 Characters

#### Legal Manufacturer

Innomotics LLC  
100 Technology Drive  
Alpharetta, GA 30005  
United States of America

Telephone: 1-877-466-8427 (1-877-IMOTICS)  
[www.portal.innomotics.com](http://www.portal.innomotics.com)

Order No. IN-MVM-BR-100-0424

© 2024, Innomotics LLC

In order to protect plants, systems, machines and networks against cyber threats, it is necessary to implement – and continuously maintain – a holistic, state-of-the-art industrial security concept. Innomotics' products and solutions constitute one element of such a concept.

Customers are responsible for preventing unauthorized access to their plants, systems, machines and networks. Such systems, machines and components should only be connected to an enterprise network or the internet if and to the extent such a connection is necessary and only when appropriate security measures (e.g. firewalls and/or network segmentation) are in place.

Innomotics' products and solutions undergo continuous development and updates, which adherence to are required to ensure the optimal security of the product and services. For more information and updates, please visit : [www.innomotics.com/cybersecurity](http://www.innomotics.com/cybersecurity).

This document contains a general description of available technical options only, and its effectiveness will be subject to specific variables including field conditions and project parameters. Innomotics does not make representations, warranties, or assurances as to the accuracy or completeness of the content contained herein. Innomotics reserves the right to modify the technology and product specifications in its sole discretion without advance notice.

The Siemens Businesses **Large Drives Applications** and **Low Voltage Motors** have been transferred to **Innomotics**. The brand change from Siemens to Innomotics is ongoing.

Siemens' or Innomotics' legal information, trademarks or logos contained in product related documents **do not necessarily represent the actual branding** used for the products. Any technical product information remains valid **independently of the brand**.

**Orders** received as of **August 1, 2024**, will be confirmed exclusively with the product mark "**Innomotics**" regarding the concerned products and services.

Independent of the order date, all ordered products or services with **delivery** dates from **April 1, 2025**, will be delivered with the product mark "Innomotics".